

	MATERIAL	PLATING
center pin	copper	nickel
metal case	copper	nickel
outer spring contact	copper	nickel
plastic	PPA	

所有权信息:
 本文件所有权属于 GLOBTEK 公司, 任何整体和部分的复制都是禁止和非法的, 除非取得 GLOBTEK 公司的授权允许。
 PROPRIETARY INFORMATION:
 PROPRIETARY OF GLOBTEK, INC. ANY REPRODUCTION, DISCLOSURE OR USE OF THIS DRAWING IN WHOLE OR PART, IS HEREBY PROHIBITED EXCEPT AS SPECIFIED IN WRITING BY GLOBTEK, INC.

REVISION			
REV	DESCRIPTION	DATE	APPROVED
A	Initial Release	2018.03.26	JET
B	Update drawing from chip to outer spring contact	2019.04.09	JET
C	Update drawing with determination the mating depth and the distance of the contacts from the opening	2020.02.20	NF
D	Remove contact resistance between terminal in closed circuit	2021.03.23	NF

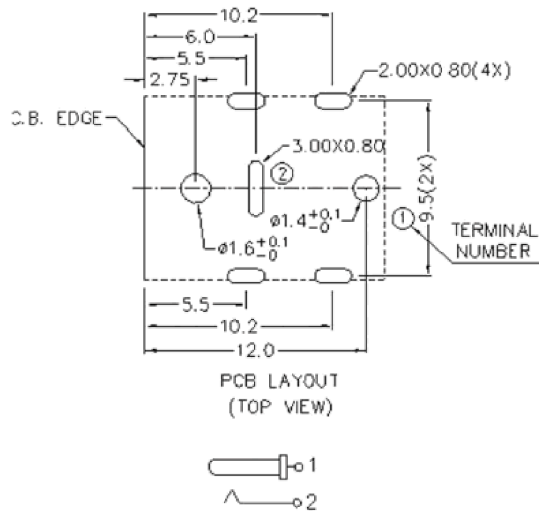
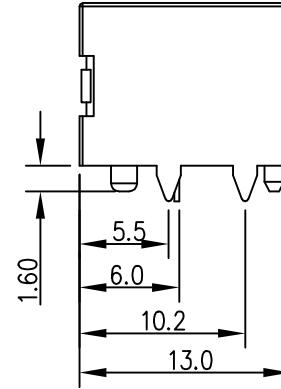
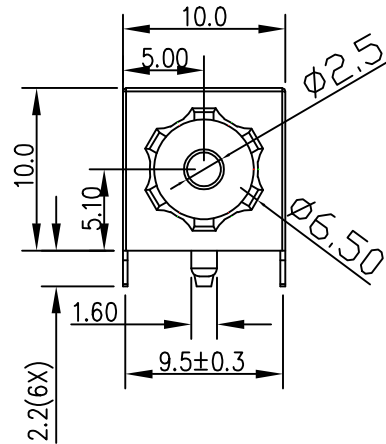
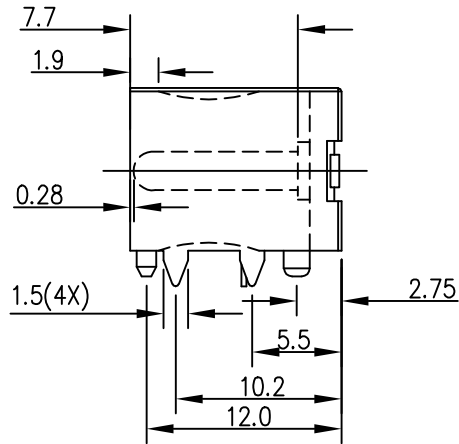

SPECIFICATIONS

parameter	conditions/description	min	typ	max	units
rated input voltage			50		Vdc
rated input current				10	A
contact resistance	between terminal and mating plug			30	mΩ
insulation resistance	at 500 Vdc	100			MΩ
voltage withstand	at 50/60Hz for 1 minute 500 Vac			500	Vac
insertion/withdrawal force		0.3		3	kg
terminal strength	any direction for 15 seconds			200	gf
operating temperature		-25		85	°C
life			5000		cycles

Note: 1. When measured at a current of less than 100 mA/1 kHz

尾注:
 Globtek 公司不对未经批准而擅自修改部件而影响的安全和性能负责, 终端用户必须参考 UL、CSA 或 EN 标准规定正确的安装。
 Foot Note:
 Globtek Inc. will not be liable for the safety and performance of these parts if unauthorized access and repair occurs. End user should consult applicable UL, CSA or EN standards for proper installation instructions

禁用:
 Globtek 产品未经授权不得用于医疗设备中以及危险环境核试验或者飞机上, 除非有 GLOBTEK 公司首席执行官的书面正式批准。
 Limitation of Use:
 Globtek product are not authorized for use as mission critical components in life support, hazardous environment, nuclear or aircraft applications without prior written approval from the CEO of Globtek Inc.

文件内容未经许可不得更改
 Contents of this document are subject to change without prior notice

Tolerance table			
RANGE	GRADE 1	GRADE 2	GRADE 3
0~4	+/-0.05	+/-0.1	+/-0.2
4~16	+/-0.08	+/-0.15	+/-0.3
16~64	+/-0.12	+/-0.25	+/-0.5
64~250	+/-0.25	+/-0.4	+/-0.8

PART NO 零件号:	/	
MODEL NO 型号:	/	
Drawn and Checked By:	Bruce	Tolerances: Grade 3
Double Checked By:		
Approved By:	Jet	

GlobTek(Suzhou), Co.,Ltd
 Tel: +86-512-6279-0301 Fax: +86-512-6279-0355 Web: www.globtek.cn

DRAWING FOR WIRE P/N:
JACK-L-PC-10A-RA(R)

A, Rev.C SHEET 1 OF 1



Thermal Design for High Current PCB-Mount Barrel Jacks

GlobTek Inc. 2019

The below information pertains to the following GlobTek parts:

- JACK-L-PC-10A-RA(R)
- JACK-C-PC-10A-RA(R)

GlobTek's JACK-L-PC-10A-RA(R) and JACK-C-PC-10A-RA(R) jacks carry a 10A continuous current rating, allowing a high current connection to be made directly to the target PCB. The contacting interface in an electrical connection is never perfect, leading to an equivalent *contact resistance* at the junction of the male and female connectors.

Robust connectors, like GlobTek's 10A PCB-mount jacks, have low values of contact resistance. Even so, at high operating currents, this resistance is not negligible and causes heating in the connector. Operating the connector at excessive temperatures can cause damage to the connector, the PCB, and poses a potential safety risk.

Therefore, it is important to assess whether additional measures are required to keep the jack at a safe operating temperature. The main contributing factors are:

1. Ambient temperature
2. Maximum continuous current

The most straight-forward approach is to provide heatsinking via additional PCB copper area near the connector. This increased surface area allows for better cooling via natural convection. The required copper area depends largely on the the application.

GlobTek produced a thermal evaluation board to test the effectiveness of PCB heatsinking in this application. (Image shown on next page.) Using the smallest PCB area (*22.0 x 28.0mm on front and back sides*), testing showed that it was possible to pass 10A through the connector, at 55°C, with no degradation to the connector during a 24 hour test. Under these conditions, the connector center pin temperature, reaches just over 130°C. Therefore, if using GlobTek's jacks in a similar scenario, it is important to consider the maximum operating temperature of the PCB. Use of a 130°C minimum operating temperature rated board is required.

If using GlobTek's PCB-mount barrel jacks with a higher ambient temperature, 85°C for example, the following solutions may be applied:

1. Increased PCB copper area (*especially on higher resistance center pin plane*)
2. Increased copper thickness
3. Increased PCB operating temperature rating

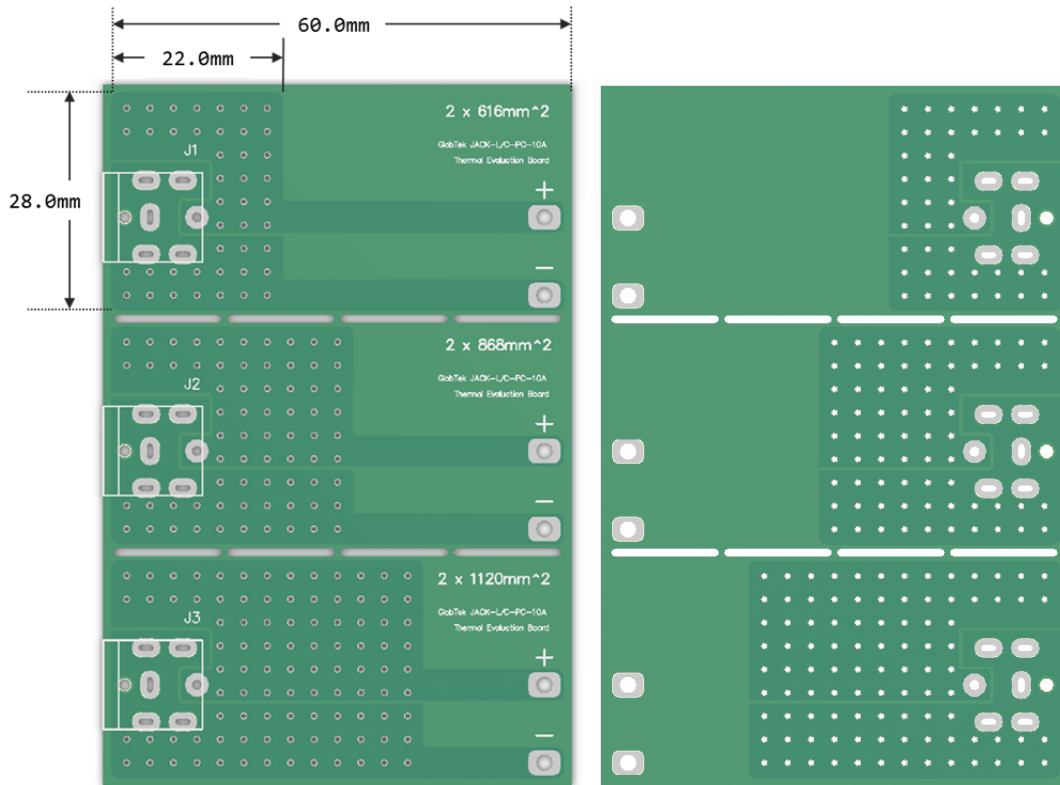

Above: GlobTek Thermal Evaluation Board for JACK-L-PC-10A-RA(R) and JACK-C-PC-10A-RA(R)
Copper thickness: 2oz (0.071mm)

Sample PCBs for customer thermal evaluation are available upon customer request to GlobTek, a small service charge may be applied.

Please note, the sample PCB has options for 3 different copper areas. The 22 x 28mm copper area evaluation board, has been tested under various conditions, see following page for thermal data. The largest board on the bottom, has approximately twice the copper area.

Date: 05-Nov-2018

CONNECTOR TEMPERATURE MEASUREMENT SUMMARY

USED PSU P/N:

TR9KE9000CCP-IM(R6B)

TR9KE9000LCP-IM(R6B)

Connector's P/N:

JACK-C-PC-10A-RA(R) 2.1mm

JACK-L-PC-10A-RA(R) 2.5mm

Test condition A

CONNECTOR P/N	Ambient Temp	Load	Total Hours	CENTER Pin_Highest temp reading	SHELL_Highest temp reading
JACK-C-PC-10A-RA(R) 2.1mm	55°C	10A	22.86	116.4°C	88.9°C
JACK-L-PC-10A-RA(R) 2.5mm	55°C	10A	22.86	132.8°C	97.6°C

Test condition B

CONNECTOR P/N	Ambient Temp	Load	Total Hours	CENTER Pin_Highest temp reading	SHELL_Highest temp reading
JACK-C-PC-10A-RA(R) 2.1mm	85°C	8A	25.11	156.54°C	116.31°C
JACK-L-PC-10A-RA(R) 2.5mm	85°C	8A	25.11	141.97°C	115.88°C

Test condition C

CONNECTOR P/N	Ambient Temp	Load	Total Hours	CENTER Pin_Highest temp reading	SHELL_Highest temp reading
JACK-C-PC-10A-RA(R) 2.1mm	85°C	10A	21.45	176.14°C	128.89°C
JACK-L-PC-10A-RA(R) 2.5mm	85°C	10A	21.45	177.46°C	134.33°C

All testing done with thermal chamber with still air, and with 22x28mm copper area top and bottom side, 2 oz copper.

Tested by: EV

CONNECTOR EVALUATION BOARD & TEST SET-UP PHOTOS

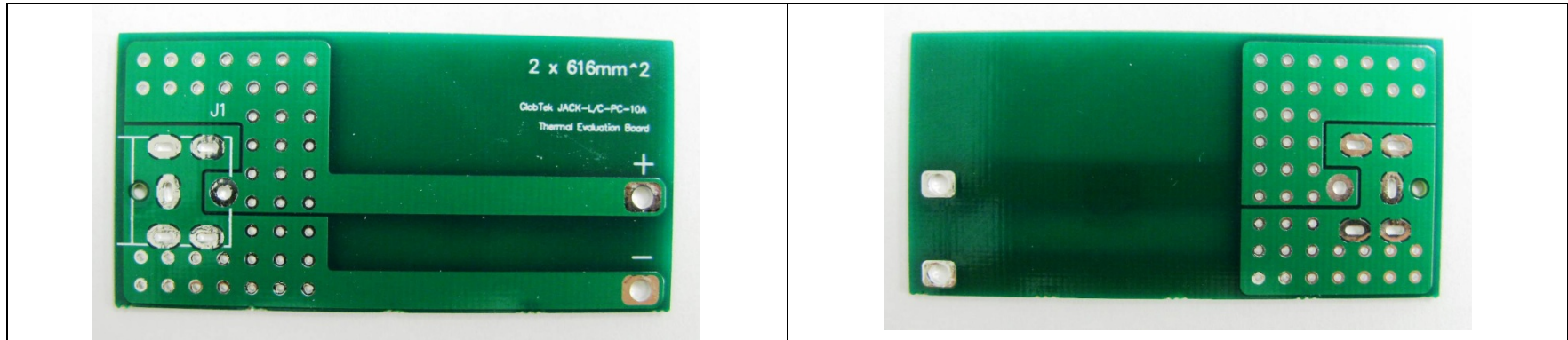

LOBTEK RECOMMENDED MOUNTING BOARD FOR THE CONNECTORS

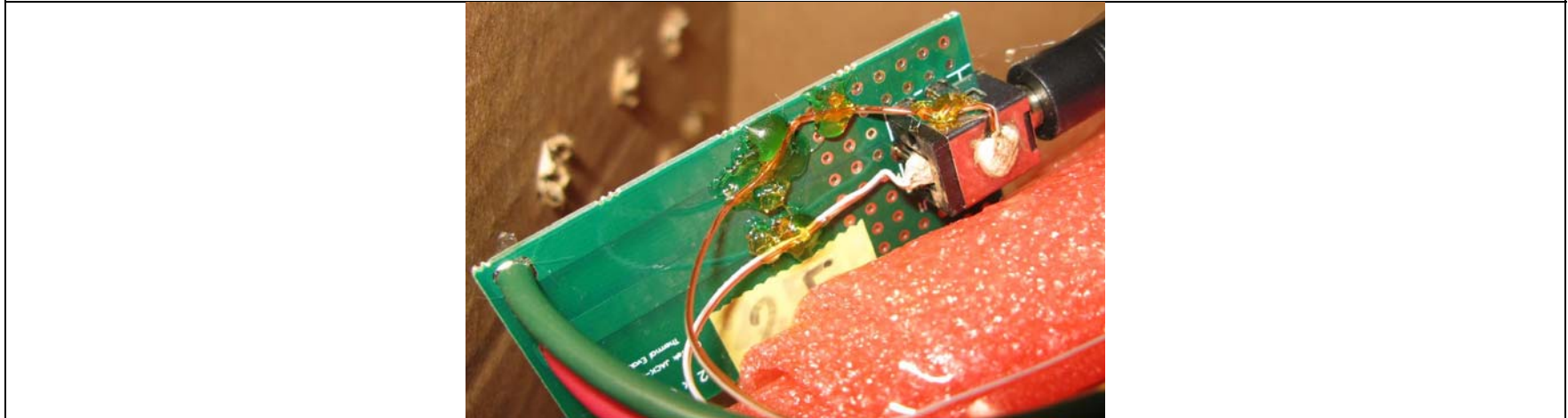

Note, maximum hotspot temperature on the PCB will be approximately 10°C cooler than the hot spot on the center pin, due to thermal gradient along the pin length as it merges into the large copper plane area.

Suggested board operating temperature rating (*please confirm in end application, with thermal probes*)

Condition A - 130°C or 140°C

Condition B - 150°C or 160°C

Condition C - 170°C or 180°C

Tested by: EV